



SQ Flex Pumps

Grundfos

SQ Flex

The Grundfos SQ Flex pumping systems are a giant leap forward for solar water pumping. Grundfos, the world's largest pump manufacturer, has reduced the cost of the pumps along with reducing the power needs. The result is a Grundfos centrifugal or helical rotor quality system for about the cost of a diaphragm pump. The Grundfos SQ Flex pumping system can also be powered by a wind generator if you have the right site. The Whisper H-80 Waterpumper on page 53 is the required generator.

Features:

- Up to 390 foot head applications • 30-300 VDC, or 90-240 VAC single-phase AC input.
- Permanent magnet high efficiency motor • Overload protection • Over temperature protection • Dry running protection
- Maximum Power Point Tracking to optimize pump operation according to DC Power available.
- Power line communication with the CU200 (optional) to display operational conditions

Model	TDH Range (Ft.)	Nominal GPM	Length (In.)	Output Size	MSRP
3 SQF-2	120 - 390	3	47	1" NPT	\$1,475.00
6 SQF-2	120 - 390	6	48	1" NPT	\$1,475.00
11 SQF-2	40 - 300	11	49	1 1/4" NPT	\$1,475.00
25 SQF-3	0 - 40	25	33	1 1/2" NPT	\$1,475.00
25 SQF-6	0 - 60	25	35	1 1/2" NPT	\$1,475.00
40 SQF-3	0 - 20	40	37	2" NPT	\$1,475.00
75 SQF-3	0 - 40	75	39	2" NPT	\$1,475.00

Accessories:

IO 100 – Simple On/Off switch box for Grundfos SQFlex solar electric system. No float switch terminals.

*Use CU200 pump controller for the Grundfos SQ Flex if a float switch is needed.

MSRP

\$109.00

IO 101 – Generator Interface Box for Grundfos SQFlex. Includes On/Off switch (replaces IO 100) and allows for operation of SQFlex pump for either solar or manual-start generator. No float switch terminals. *Add a CU200 pump controller for the Grundfos SQFlex if a float switch is needed.

\$327.00

IO 102 – Wind Generator Breaker Box. This box includes a rectifier for the wind generator and a stop switch, and allows the Grundfos SQFlex pump to operate from either the H80 wind generator or a combination of wind and solar. *Add a CU200 pump controller for the Grundfos SQFlex if a float switch is needed.

\$319.00

CU 200 – SQFlex Control Box. This controller and system monitor can be used with solar alone or in combination with the IO101 (for manual generator backup) and/or the IO102 (for wind generator). The CU200 will allow you to add a float switch to shut off the pump when the storage tank is full. The system monitor display on the CU200 shows the following:

\$245.00

- Pump operation • Full Tank • Input Power (Watts)
- Alarm Indicator for dry running, overvoltage, overload and overtemperature.

Water Level Switch – Mechanical float switch

\$31.00

GF 43 Solar Module – 43 Watts, Vmp: 141, Imp: 0.31, Voc: 196.2, Isc: 0.42, Dimensions: 52" x 32", Weight: 33 lbs.

\$199.00

SQFlex Solar Application Example

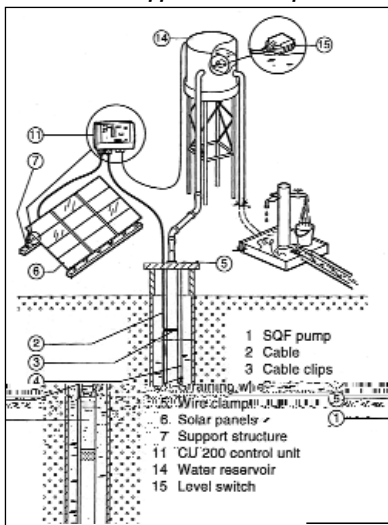

SQFlex Performance Range

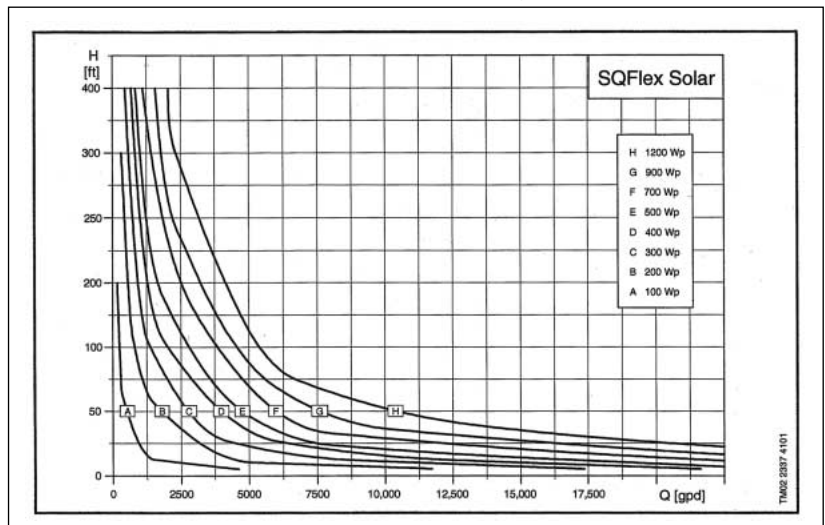

Water Pumps



Grundfos SA-1500

Grundfos

SA-1500

The Grundfos solar direct SP line of water pumps should be considered by anyone who wants to do the job right the first time. The pumps are a stainless steel centrifugal design with no diaphragms to replace and a water-cooled motor.

The Solar Pump 1500 series operates from a solar array of 7 or 8 modules in series up to 2000 watts. This series can pump water from a maximum depth of 650 feet. Common applications for this series of the Grundfos Solar Pump 1500 are campground water systems, livestock watering, irrigation, and larger community water systems.

The SA-1500 controller is a pump controller and an inverter. There are many pump control features in the controller such as maximum power point tracking, low water sensing, and float switch terminals. This controller takes the DC power from the solar array and inverts it to 65 VAC, 3 phase for the pump motors.

Accessories:

Contact your dealer for the accessories to complete your water pumping systems.

- A solar array tracker; using a tracker on a water pumping system may increase your water production up to 25%
- Submersible pump cable • Float switches • Solar modules

SOLAR PUMP 1500 PUMPS	Voltage VDC	Current	Power Wp	Flow Rate GPM	Total Vertical Lift (in feet)	Weight (lbs)	MSRP
08045028 SP1 A-28	105 to 120	14A	2000	3 to 9	328 to 656	39.9	\$1,315.00
03315021 SP1.5 A-21	105 to 120	14A	2000	7 to 12	262 to 394	37	\$1,290.00
09315015 SP2 A-15	105 to 120	14A	2000	7 to 20	164 to 394	34.8	\$1,199.00
10315010 SP3 A-10	105 to 120	14A	2000	17 to 37	98 to 230	32.2	\$1,112.00
11875005 SP8 A-5	105 to 120	14A	2000	40 to 140	7 to 92	32.9	\$1,112.00
07315003 SP14 A-3	105 to 120	14A	2000	80 to 180	7 to 49	42.1	\$1,224.00
CONTROLLER							
625100 SA1500 Controller	105 to 120	14A	2000			9.7	\$1,558.00
CABLE TERMINATION KIT							
115099 Cable termination kit w/sock							\$126.00

WINDPOWER & WATER PUMPS

Water Pumps



Grundfos *continued*

Grundfos Solar Pump Sizing Chart

Water production based on 4 kwh/m2 Winter and 6 kwh/m2 Summer insolation (POA)
Trackers will increase daily water production 25-30% above listed values.

Head/ Wattage	270 W	360 W	540 W	690 W	920 W	1150 W	1200 W	1365 W	1575 W	1800 W	1920 W
30 ft./ 10M	11SQF-2	25SQF-3	25SQF-3	40SQF-3	75SQF-3	75SQF-3	14A-3	14A-3	14A-3	14A-3	14A-3
Summer GPD	3,700	5,100	8,100	11,000	15,450	18,700	20,600	23,770	27,310	30,270	31,700
Winter GPD	2,500	3,000	5,200	6,850	9,990	12,500	12,490	14,950	18,150	21,130	22,720
Max Flow	8	14	20	28	37.5	45	64.5	70.4	77	83.6	85.8
50 ft./ 15M	11SQF-2	11SQF-2	11SQF-2	25SQF-6	25SQF-6	25SQF-6	8A-5	8A-5	8A-5	8A-5	8A-5
Summer GPD	3,100	4,000	5,300	7,150	9,550	11,700	12,500	15,850	17,880	20,520	21,740
Winter GPD	2,000	2,700	3,900	4,400	6,250	8,000	7,750	9,550	11,680	13,810	14,900
Max Flow	7.5	9	10	18	22.5	26	43	50.2	54.6	57.2	59
65 ft./ 20M	11SQF-2	11SQF-2	11SQF-2	11SQF-2	25SQF-6	25SQF-6	8A-5	8A-5	8A-5	8A-5	8A-5
Summer GPD	2,700	3,600	4,900	5,550	7,650	9,700	9,500	10,500	13,000	16,640	17,680
Winter GPD	1,700	2,350	3,450	4,200	4,750	6,300	5,000	6,000	7,750	9,850	11,070
Max Flow	7	8	9.5	10.5	20	24	38	40	45	51.7	53.7
95 ft./ 30M	11SQF-2	11SQF-2	11SQF-2	11SQF-2	11SQF-2	11SQF-2	3A-10	3A-10	3A-10	3A-10	3A-10
Summer GPD	1,700	2,450	3,800	4,700	5,350	5,650	6,500	7,000	8,250	9,000	9,500
Winter GPD	900	1,450	2,500	3,300	4,100	4,450	3,750	5,000	6,750	6,250	7,500
Max Flow	5	7	9	10	10	10	19	20	21	23	24
130 ft./ 40M	11SQF-2	11SQF-2	11SQF-2	11SQF-2	11SQF-2	11SQF-2	3A-10	3A-10	3A-10	3A-10	3A-10
Summer GPD	1,100	1,600	2,800	3,800	4,650	5,100	4,960	5,940	6,890	7,500	8,250
Winter GPD	600	850	1,700	2,450	3,350	3,900	2,850	3,510	4,320	5,000	5,500
Max Flow	3	5	8	10	10	10	17.6	19	21.1	22	23
160 ft./ 50M	6SQF-2	6SQF-2	11SQF-2	11SQF-2	11SQF-2	11SQF-2	3A-10	3A-10	3A-10	3A-10	3A-10
Summer GPD	900	1,300	2,200	3,100	4,100	4,600	3,670	4,570	5,570	6,630	7,180
Winter GPD	500	800	1,250	1,900	2,750	3,450	1,680	2,190	3,110	3,990	4,320
Max Flow	3	4	7	8	9	9	15.4	17.2	19.1	20.5	21.1
195 ft./60M		6SQF-2	6SQF-2	11SQF-2	11SQF-2	11SQF-2	2A-15	2A-15	3A-10	3A-10	3A-10
Summer GPD		1,100	1,800	2,400	3,450	4,050	2,770	3,370	4,170	4,960	5,570
Winter GPD		600	1,100	1,400	2,150	2,800	1,420	1,770	1,980	2,850	3,140
Max Flow		3	5	7	9	9	10.5	11.4	16.3	18.1	19
225 ft./70M			6SQF-2	6SQF-2	11SQF-2	11SQF-2	2A-15	2A-15	2A-15	2A-15	3A-10
Summer GPD			1,600	2,000	2,750	3,550	2,110	2,640	3,370	3,870	4,540
Winter GPD			950	1,350	1,600	2,250	730	1,100	1,610	2,190	2,190
Max Flow			4	5	8	8	9.3	10.5	11.8	12.6	15.7
260 ft./80M			6SQF-2	6SQF-2	6SQF-2	11SQF-2	2A-15	2A-15	2A-15	2A-15	2A-15
Summer GPD			1,350	1,800	2,200	2,950	1,630	2,110	2,770	3,370	3,570
Winter GPD			750	1,150	1,600	1,700	320	730	1,210	1,740	1,870
Max Flow			4	4	5	8	8.1	9.3	10.5	11.8	12.3
295 ft./ 90M			6SQF-2	6SQF-2	6SQF-2	6SQF-2	1.5A-21	2A-15	2A-15	2A-15	2A-15
Summer GPD			1,100	1,600	1,950	2,200	1,320	1,790	2,370	2,900	3,190
Winter GPD			600	950	1,400	1,700	450	480	1,010	1,400	1,580
Max Flow			3	4	5	5	6	8.5	9.7	11	11.6
325 ft./ 100M			3SQF-2	6SQF-2	6SQF-2	6SQF-2	1.5A-21	1.5A-21	2A-15	2A-15	2A-15
Summer GPD			1,000	1,400	1,800	2,100	1,050	1,710	1,980	2,560	2,770
Winter GPD			700	800	1,250	1,550	200	450	600	1,050	1,260
Max Flow			2	4	4	5	5.5	6.3	8.8	9.9	10.5
425 ft./130M							1A-28	1A-28	1A-28	1A-28	1A-28
Summer GPD							870	1,050	1,340	1,630	1,770
Winter GPD							165	420	630	870	970
Max Flow							3.9	4.5	5.1	5.5	5.7
490 ft./ 150M								1A-28	1A-28	1A-28	1A-28
Summer GPD								790	1,050	1,320	1,450
Winter GPD								165	420	590	710
Max Flow								3.9	4.5	4.9	5.1
655 ft./ 200M											1A-28
Summer GPD											790
Winter GPD											165
Max Flow											3.7

WINDPOWER & WATER PUMPS